

HH Harro Höfliger

[ALL YOU NEED]

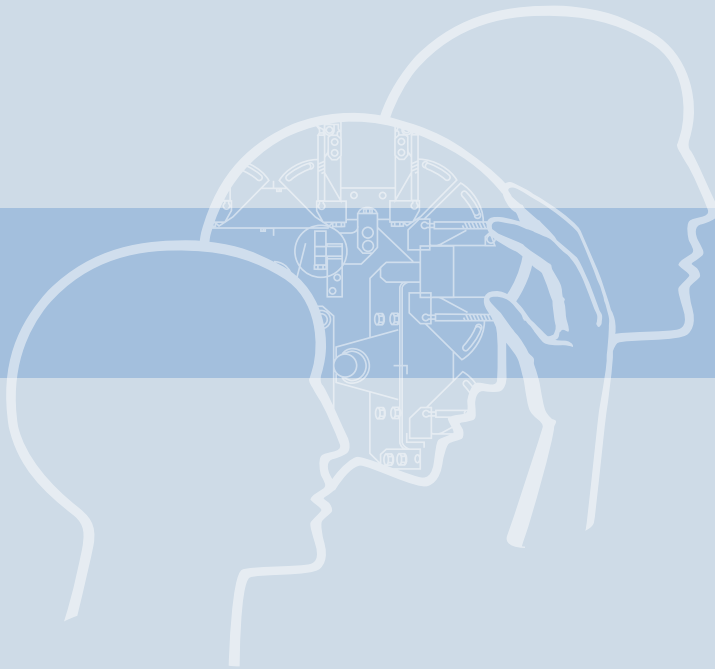

OmniControl

Sizepart-free
100%-checking system
for tablets and capsules

A member of
Excellence United

OmniControl – the modular control system for maximum flexibility in the weighing process of solid products.

An essential requirement to launch a drug to the market is the precise dosing of the active ingredient quantity. Therefore during the production of the preparation highly accurate measurements are of the greatest importance.

OmniControl – the most extensive format-independent control system for capsules and tablets – is revolutionizing the quality control of solid delivery forms.

The OmniControl system completes the innovative machinery program for the processing of capsules and tablets. As with the Modu-C capsule filler, special emphasis is placed on modularity and flexibility.



TABLETS

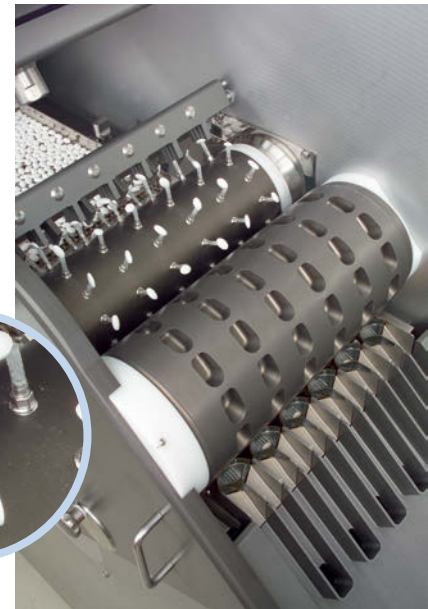

6-track version of the machine

6 or 12 tracks

CAPSULES



12-track version of the machine

Precision which pays off – with WIPOTEC weighing technology:
The control system for direct and absolute weight determination of pharmaceutical capsules and tablets.

Exchange parts



Vacuum suction wheel:
For picking up solids

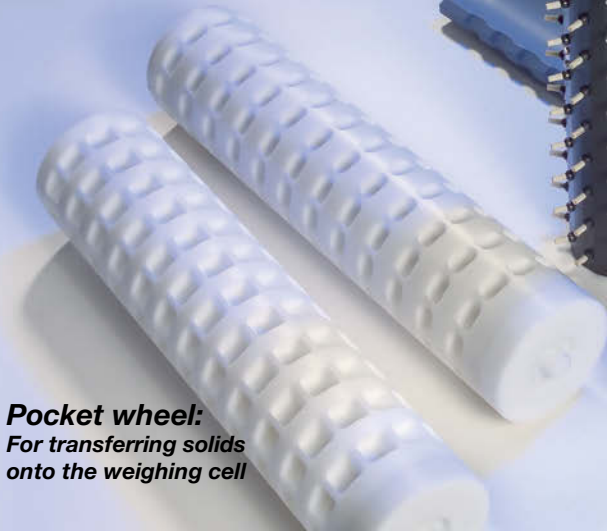

Pocket wheel:
For transferring solids
onto the weighing cell

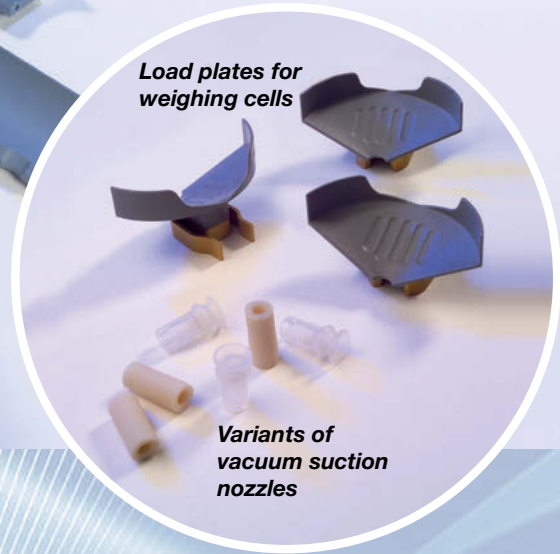

**Load plates for
weighing cells**

**Variants of
vacuum suction
nozzles**

OmniControl – the forerunner in flexibility

- + As a rule a multitude of products from the fail product scrap from tablet presses can be verified as pass-products. The OmniControl system is predestined for recovering those pass-products.
- + OmniControl stands for weight determination with faultless sorting out of fail-products.
- + The OmniControl system can be implemented as complementary checking stage for tablet presses without 100%-pressing force control.
- + In addition to pressed tablets, compressed tablets engineered with different technologies, such as e.g. extruded tablets, may be checked as well.
- + Independent of geometry and dimension: Products with irregular or asymmetrical shapes are checked without any problem.
- + The sizepart-free process yields maximum flexibility in operation and maintenance of the control system.
- + Smooth process sequence – no product jam in the trays or size-dedicated function components.

A revolution in checking technology



The OmniControl Principle – simply ingenious.

High-precision engineering for challenging processes and products:

The basic idea of the OmniControl system rests on a sizepart-free infeed facility, mass determination and the sorting process. The control of pharmaceutical solid products such as capsules, tablets and coated tablets follows the gravimetric weight assessment.

Focus on the good product:

OmniControl complies with the highest pharmaceutical standards due to its consistent pass-product philosophy. The system's linchpin is a pass/fail sorting process controlled directly by the weighing cell. The rotational movement of the starwheel for the purpose of sorting pass and fail products has motorized triggering and monitoring. The direction of rotation is defaulted and monitored by the weighing cell (based on the assessment of mass/ weight).

The patented rotating star – the safety center in the OmniControl:

The ingeniously simple rotating star concept guarantees 100% product quality. The tablets or capsules are subject to a positive and complete forced guidance. The pocket wheel hands the product over to the rotating star. After weight assessment, the pass-products advance to the left into the pass-product container, while overweight/underweight products travel to the right and feed into the fail-product bin. The rotating star movement provides for the countercheck. Erroneous rejects are a thing of the past.

Function principle of mass control via gravimetric assessment:

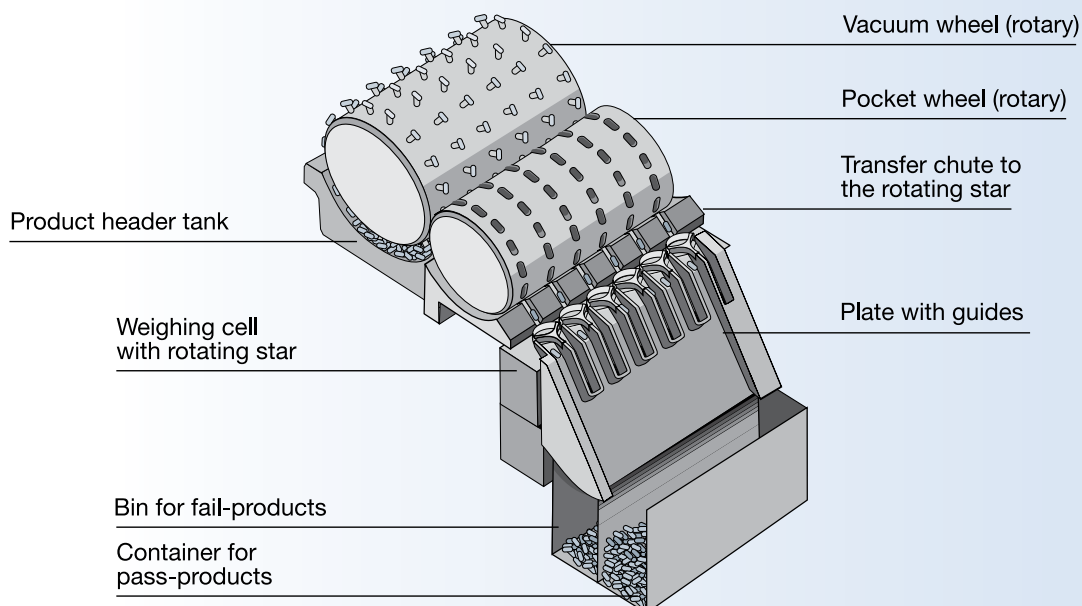

Sizepart-free weight assessment process:

- Step 1:** No sizeparts are required due to picking up the product from the supply hopper via a vacuum wheel.
- Step 2:** The products are transferred directly from the vacuum wheel into a pocket wheel.
- Step 3:** The pocket wheel conveys the products onto the weighing cell. At this point weight assessment takes place.
- Step 4:** After evaluation of the weight data the rotating wheel divides the products according to pass or fail.

Pharmaceutically secure discharge:

Weighing process with pass-product discharge

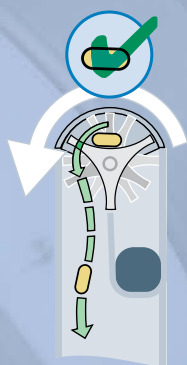

Weighing process with fail-product ejection

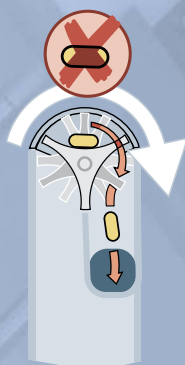

The sizepart-free technique of OmniControl at a glance.

OmniControl – the technical highlights:

- Suitable for gross-weight determination of tablets and capsules.
- Two performance classes for low and mid-speed (32.500 / 65.000 p/h).
- Sizepart-free infeed system, weight determination and product singularization.
- Logically structured operator guidance of the operator control panel (HMI with a 15" touch panel).
- Low-noise operation due to rotary conveyor and control system.
- No costs for purchasing and storage of various sizepart sets
- Machine setup times for different product sizes are no longer necessary.
- Fast assembly / disassembly for cleaning product-contact parts.
- Maintenance-free drive units.
- Optional wet cleaning of all product-contact parts.
- Separation of production and machine spaces.

No limits to format freedom:

The patented vacuum wheel transfers tablets and capsules of the most diverse of sizes into the weighing pan.



SPECIFICATIONS

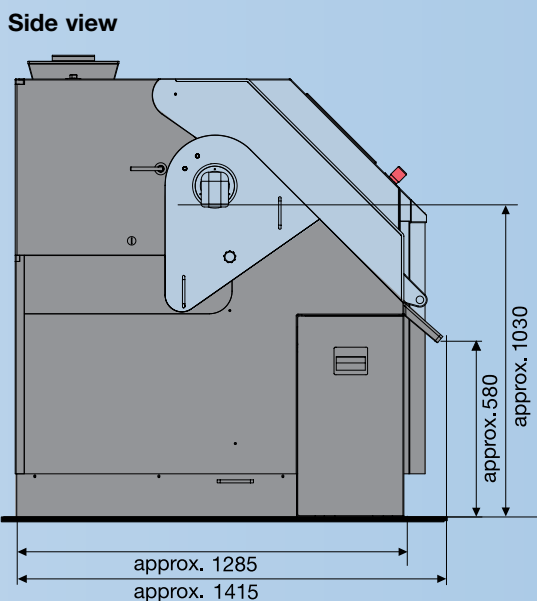
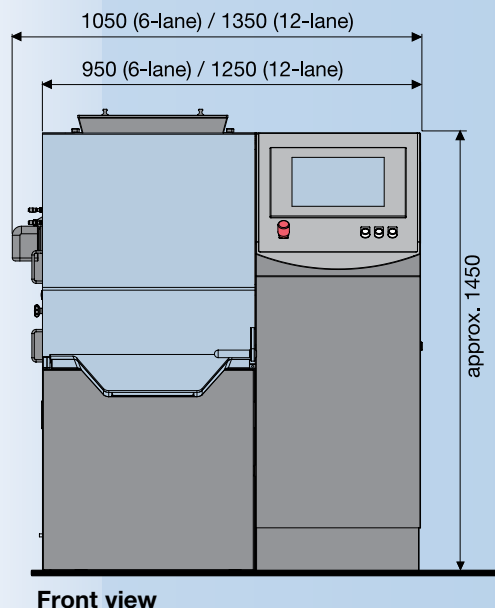

Tablet shapes*			Tablet cross-sections*	Hard gelatine capsules*
round	oblong	polygonal		
	 max. 21 mm			 max. 21 mm
				 **
			Notch Lateral side	
			 Surface	

"Format freedom" tested for *standard geometries within specified **dimensions

Technical data

Output: 32,500 to 65,000 products/h ⁽¹⁾

Lanes: 6, 12

Max. cycle frequency: 90 per minute ⁽²⁾

Measuring range: 0 – 2,000 mg

Weighing accuracy: ± 2 mg ⁽³⁾

Temperature range: 18°C - 30°C

Max. product length: 21 mm

(1) Dependent on product dimensions and characteristics

(2) Dependent on size and required accuracy

(3) Dependent on size and speed

All information contained in this leaflet are without obligation and are subject to modifications without prior notice!

Weight: approx. 1150 kg

Electric specifications: 230/400 V, 50 Hz, 3 P/N/PE

Power consumption: approx. 1.5 KVA

Compressed air: not required

Materials used:

Product-contact parts: aluminum hard-coated, stainless steel, titanium (FDA-compliant)

Machine protection: stainless steel design or PC panes



[ALL YOU NEED]

**Harro Höfliger
Verpackungsmaschinen GmbH**

Helmholtzstrasse 4
71573 Allmersbach im Tal
Telephone: +49 (0)7191 / 501-0
Telefax: +49 (0)7191 / 501-5244

www.hoeffliger.com · info@hoeffliger.com

ENGINEERED PRODUCTION SOLUTIONS