

# fuchs

Universal plansifter

## SIFTOMAT

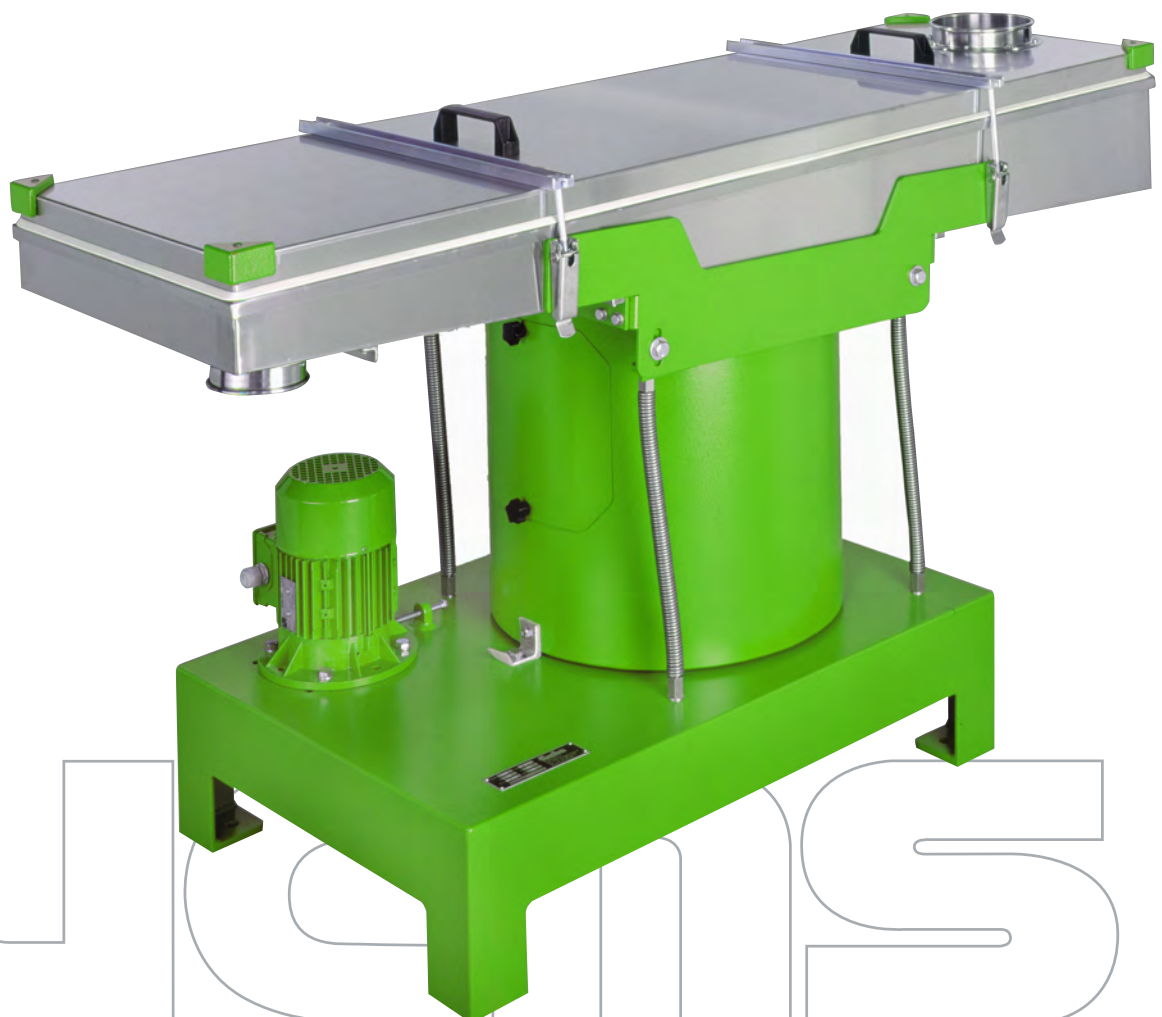
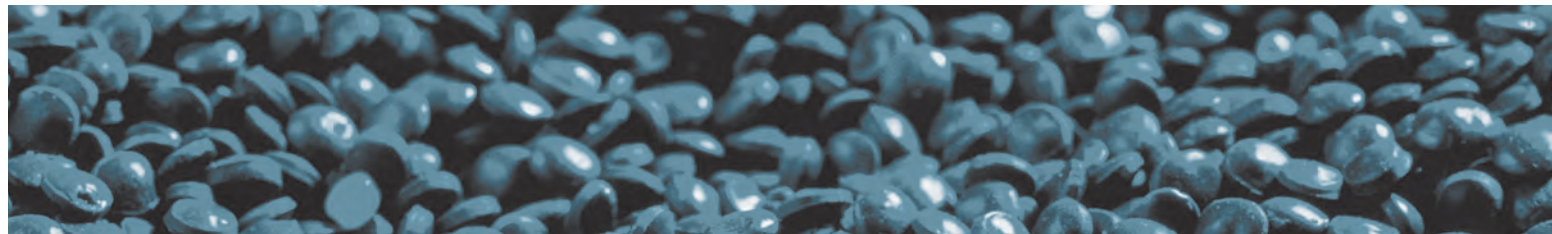

## // APPLICATIONS

- Sizing
- Control and safety sifting
- Dedusting

## // TYPICAL APPLICATIONS

- Perfect sorting "longs" and "twins" of plastic granules
- Simultaneous dedusting and control sifting of bulk products
- Control sifting of food stuff or pharmaceutical products before conditioning
- Waste separation of vegetable sticks or cubes
- Separation of cheese rasp
- Precision sizing of spices or cut mushrooms into several fractions
- Dedusting or separation of the ground cereals fines

## // USERS

- Food industry
- Pharmaceutical industry
- Chemical industry
- Animal feed industry
- Plastic industry
- Metallurgy
- etc.

## // ADVANTAGES

- Precision sifting
- High sifting capacity per square meter of sieve
- Up to 4 fractions in one pass
- Quiet operation, almost without vibration
- 7 standard sieve sizes for optimal product processing
- Extremely gentle sifting of the product
- Very easy replacement of the sieve screens
- Very easy to clean
- Optimal hygiene
- Extremely easy to maintain
- Excellent cost/performance ratio

## // WORKING PRINCIPLE

The horizontal circular movement of the plansifter, combined with its adjustable slope, ensures gentle treatment of the product passing over the screen. The coarse components pass over the screen, the finer components falling through the mesh.

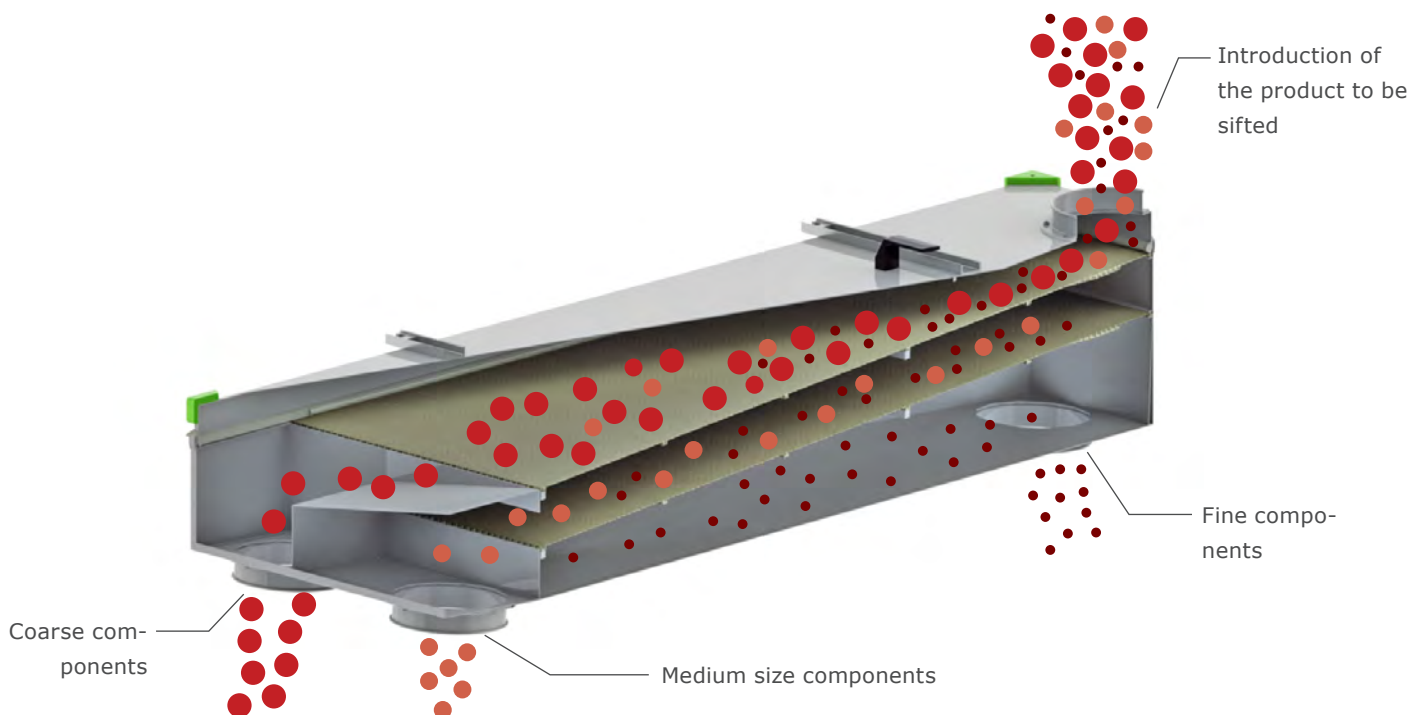

Working principle of a two levels type K sieve

## // SIEVE DIMENSIONS

The universal **SIFTOMAT** plansifters are available in 7 different standard sizes:

SIFTOMAT Size	Sieve dimensions l x w [mm]	Sieve area [m <sup>2</sup> ]
1	800 x 400	0,32
2	1110 x 480	0,53
3	1383 x 480	0,66
41	1383 x 720	0,99
51	1840 x 720	1,32
6	1383 x 960	1,32
7	1840 x 960	1,76

## // SIEVE CLEANING SYSTEMS

The sieve cleaning systems prevents the plansifter from clogging up.

### Rubber balls sieve cleaning system

The plansifter may be fitted with an efficient rubber balls cleaning system when the products to be sifted tend to clog up the sieve meshes. This system uses a special frame placed directly underneath the sieve and containing rubber or polyurethane balls. The oscillating movement of the frame projects these balls against the sieve for efficient cleaning.

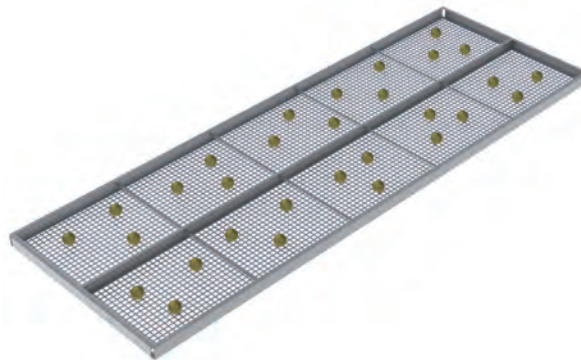

### Ultrasonic sieve cleaning system for fine mesh sieves of less than 300 µm

This system vibrates the sieve at an ultrasonic frequency. The waves generated by the system are forwarded to the sieve frame and to the sieve by means of a converter. This innovative and by **FUCHS** patented process operates at frequencies varying constantly between 30 and 38 kHz has proven to be extremely efficient when processing fine powders combined with fine mesh sieves of less than 300 µm. This process prevents the sifter sieve from clogging up and increases the sifter throughput.

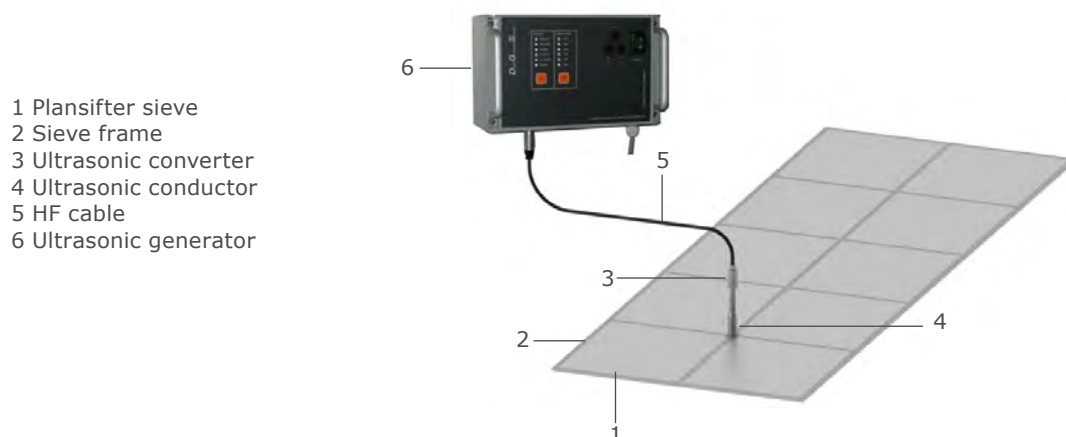

## // STANDARD PLANSIFTERS

The sifters described in this flyer are available in various sizes and executions.

Example: **SIFTOMAT 3 P 2S + 1R**

This size 3 type 2 universal plansifter with two sieves is fitted with a rubber balls sieve cleaning system placed underneath the lower sieve which uses the finest available mesh. The following plansifter models are available in the standard sales program:

Size and type	1S+0R	1S+1R	2S+0R	2S+1R	2S+2R	3S+0R	3S+1R	3S+2R	3S+3R
1 P	S-1P10-01	S-1P11-01	S-1P20-01	S-1P21-01	S-1P22-01				
1 K	S-1K10-01	S-1K11-01	S-1K20-01	S-1K21-01	S-1K22-01	S-1K30-01	S-1K31-01	S-1K32-01	S-1K33-01
2 P	S-2P10-01	S-2P11-01	S-2P20-01	S-2P21-01	S-2P22-01				
2 K	S-2K10-01	S-2K11-01	S-2K20-01	S-2K21-01	S-2K22-01	S-2K30-01	S-2K31-01	S-2K32-01	S-2K33-01
3 P	S-3P10-01	S-3P11-01	S-3P20-01	S-3P21-01	S-3P22-01				
3 K	S-3K10-01	S-3K11-01	S-3K20-01	S-3K21-01	S-3K22-01	S-3K30-01	S-3K31-01	S-3K32-01	S-3K33-01
41 P	S-41P10-01	S-41P11-01	S-41P20-01	S-41P21-01	S-41P22-01	S-41P30-01	S-41P31-01	S-41P32-01	S-41P33-01
41 K	S-41K10-01	S-41K11-01	S-41K20-01	S-41K21-01	S-41K22-01	S-41K30-01	S-41K31-01	S-41K32-01	S-41K33-01
51 P	S-51P10-01	S-51P11-01	S-51P20-01	S-51P21-01	S-51P22-01	S-51P30-01	S-51P31-01	S-51P32-01	S-51P33-01
51 K	S-51K10-01	S-51K11-01	S-51K20-01	S-51K21-01	S-51K22-01	S-51K30-01	S-51K31-01	S-51K32-01	S-51K33-01
6 P	S-6P10-01	S-6P11-01	S-6P20-01	S-6P21-01	S-6P22-01	S-6P30-01	S-6P31-01	S-6P32-01	S-6P33-01
6 K	S-6K10-01	S-6K11-01	S-6K20-01	S-6K21-01	S-6K22-01	S-6K30-01	S-6K31-01	S-6K32-01	S-6K33-01
7 P	S-7P10-01	S-7P11-01	S-7P20-01	S-7P21-01	S-7P22-01	S-7P30-01	S-7P31-01	S-7P32-01	S-7P33-01
7 K	S-7K10-01	S-7K11-01	S-7K20-01	S-7K21-01	S-7K22-01	S-7K30-01	S-7K31-01	S-7K32-01	S-7K33-01

## // PROVEN SWISS QUALITY

Decades of constant developments in close collaboration with users are the best warranty for a quality product, corresponding to the needs and the highest expectations of customers. The great number of **FUCHS** plansifters, some of which are being used in the most difficult conditions all over the world, speaks for itself.

**FUCHS** plansifters are successfully used worldwide in many applications. Unique for their flexibility, they offer solutions ideally adapted to the most complex problems to be solved.

## // CONSTRUCTION

The **FUCHS SIFTOMAT** plansifter is normally delivered in its enclosed, dust-tight version; other non-dusty products can be treated on the same machine but without their enclosures. The modular building concept allows wide adaptability, economic production and speedy delivery.



Closed construction



Open construction

## // SIEVE TYPES

Two types of sieves may be distinguished:

### **P type**

The P type plansifters are fitted with a sieve case, with the cover, the sieves and the bottom being aligned in parallel. The sifted products therefore leave the sifter on the side opposed to the product inlet. This arrangement is specially interesting when the sifted fractions must be kept away from the sifter inlet.

### **K type**

The K type plansifters are fitted with a conical sieve case. Only the cover and the sieves are aligned in parallel to each other. The bottom being inclined, the product fines return to the sifter outlet on the sifter inlet side. This arrangement is specially interesting with 3 or 4 fraction sifters where the product outlets must be spaced out or when the control sifting or the material flow must, to the greatest extent possible, be in a straight line. In this case, the sifted foreign fines will be separated from the normal product flow.



SIFTOMAT 3 P 1S + 1R  
SIFTOMAT size 3, type P with 1 sieve and rubber ball sieve cleaning system



SIFTOMAT 3 K 1S + 0R  
SIFTOMAT size 3, type K with 1 sieve, without rubber ball sieve cleaning system

## // SIEVES

The **SIFTOMAT** plansifter may be equipped with up to three sieves mounted on top of one another and allowing up to four fractions in one pass. The frame as well as the sieves are mainly manufactured from stainless steel. For special applications the mesh may be made from plastics. Replacing screens is very easy and may be done by a single person without any tooling.

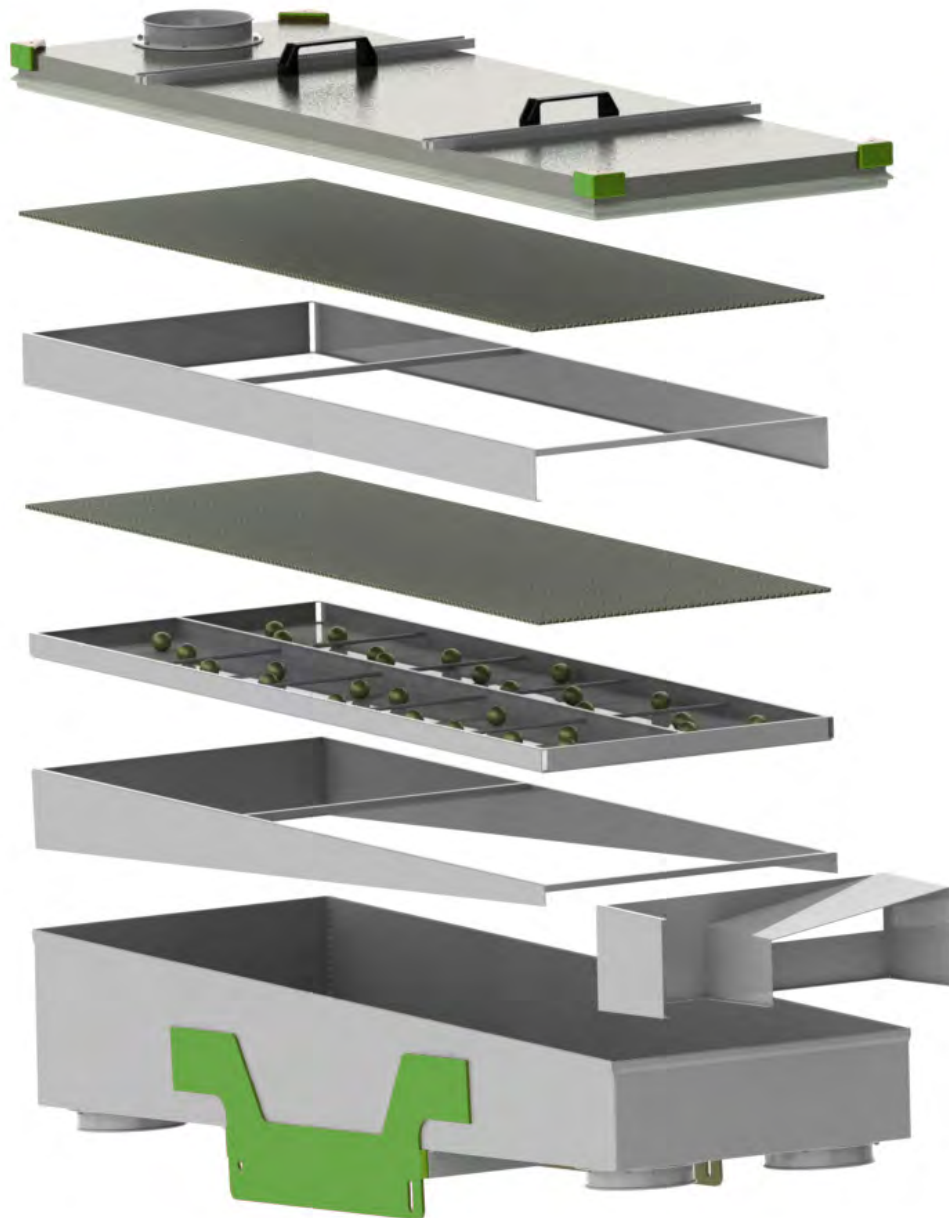

Sieve layout for a SIFTOMAT 3 K 2S + 1R: all components are easily replaceable by a single person without any tooling. This is also true for the sieve frame which may be dismounted in a few seconds without tooling (for instance to be transported to the washing room).

**// SIFTOMAT TABLE**

Type	a	b	c	d	e	f	g	h	i	k	Motor [kW]	Weight [kg]
1	960	400	780	480	400	375	240	395	700	400	0.55	170
2	1280	480	900	600	480	480	300	450	800	500	0.75	300
3	1560	480	900	600	480	480	300	450	800	500	0.75	310
41*	1560	720	900	600	480	480	300	450	800	500	0.75	350
41	1560	720	1000	700	640	530	350	530	900	600	1.10	530
51	2080	720	1000	700	640	530	350	530	900	600	1.10	550
6	1560	960	1000	700	640	530	350	530	900	600	1.10	570
7	2080	960	1000	700	640	530	350	530	900	600	1.10	590

Type	I <sub>p</sub>	I <sub>k</sub>	m	1 sieve 1/4 outlets		2 sieves 1/2/4 outlets		3 sieves 1/2/3/4 outlets		v	w	x	y	z
				n <sub>p</sub>	n <sub>k</sub>	n <sub>p</sub>	n <sub>k</sub>	n <sub>p</sub>	n <sub>p</sub>					
1	555	586	550	784	806	854	866	934	946	192	95	70	150	100
2	660	702	650	892	925	962	985	1042	1065	220	95	70	150	100
3	655	706	645	897	938	967	998	1047	1078	228	95	70	150	100
41*	668	723	658	908	950	978	1010	1058	1090	285	130	95	200	150
41	718	773	708	958	1000	1028	1060	1108	1140	285	130	95	200	150
51	712	781	700	964	1020	1034	1080	1114	1160	285	155	120	250	200
6	718	773	708	958	1000	1028	1060	1108	1140	360	155	120	250	200
7	712	781	700	964	1020	1034	1080	1114	1160	360	155	120	250	200

\* with one sieve

Sieve slope: 2% (standard)

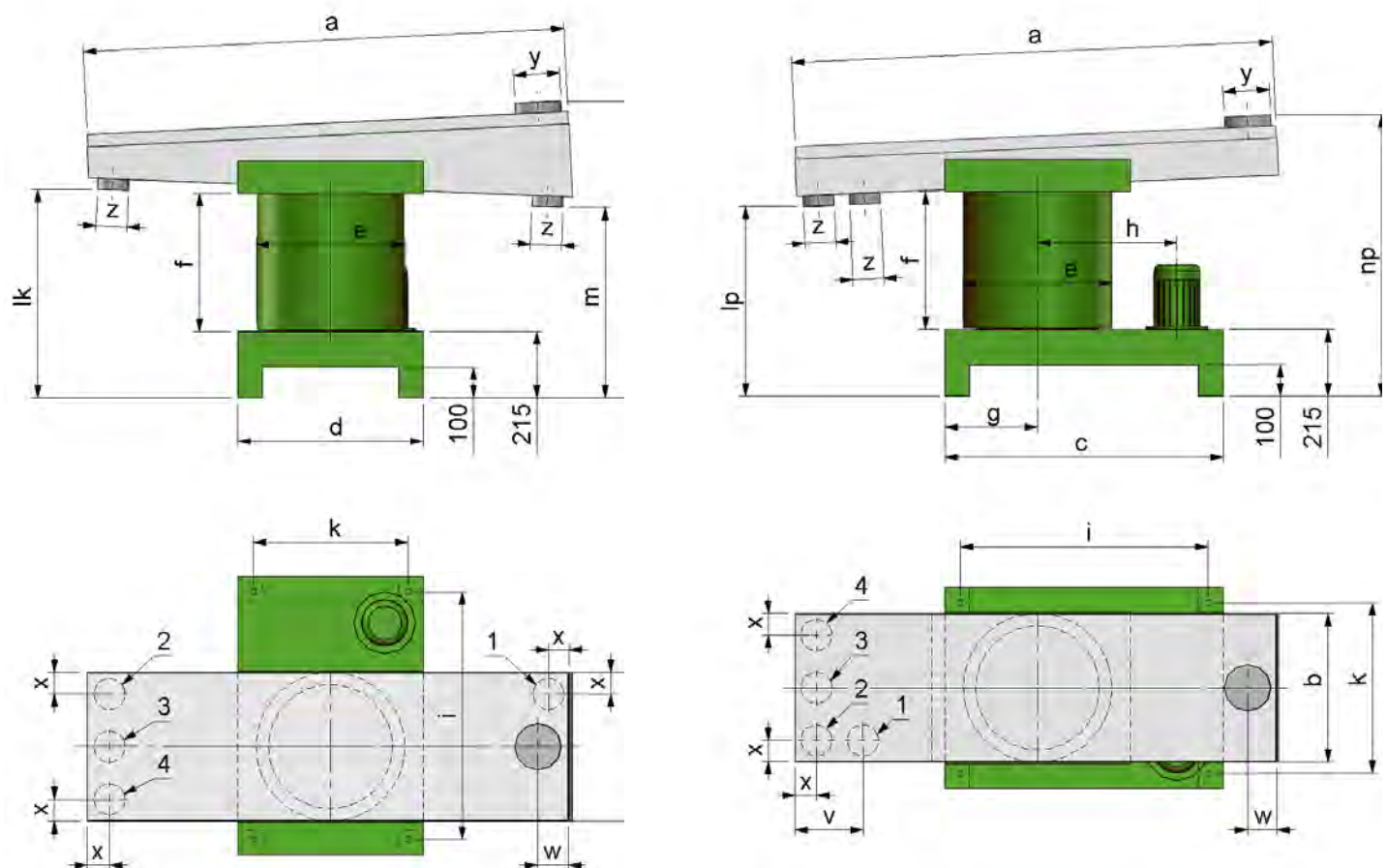

## // SPECIAL VERSION

### Mobile execution

Universal **SIFTOMAT** plansifters are easily transportable by means of a simple fork lifter. Otherwise, the **SIFTOMAT** plansifters may be fitted with a drawbar system as illustrated below. Two fixed wheels at the back of the sifter lift the machine by a few millimetres. A drawbar system can be hooked onto the machine base on the side opposed to the wheels. Lifting the sifter with the drawbar and driving the machine on three wheels is then very easy.



### PL type sifter for the pharmaceutical industry

The type **PL SIFTOMAT** plansifter has been specially developed for applications in the pharmaceutical industry and differs from the standard machine as follows:

- All machine parts that come into contact with the product are entirely manufactured from stainless steel St.1.4435
- Machine parts which do not come into contact with the product are entirely manufactured from glass pearl blasted stainless steel St.1.4301
- Laser-welded sieve frame
- Motor fully integrated in stilted machine base
- Optional integrated control unit
- Highly resistant tightening sleeve with zipper between the machine base and the driving cylinder
- No stabilisation springs (stabilisation by means of the sleeve with zipper)



### FUCHS Maschinen AG

Englisberg 17  
CH-1763 Granges-Paccot, Schweiz

Telefon +41 26 510 10 00  
Fax +41 26 510 10 09  
info@fuchsag.com

[www.fuchsag.com](http://www.fuchsag.com)